

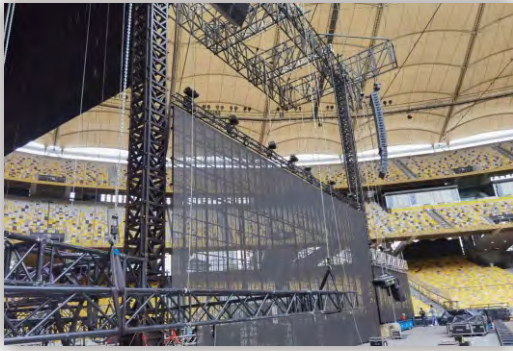

广东科励宝舞台科技有限公司  
Guangdong Coreat Stage Technology Co., Ltd

## 环链葫芦 · 控制系统 · 解决方案

CHAIN HOISTS • CONTROL SYSTEMS • SOLUTIONS





# CHAIN HOISTS





科励宝走向世界，产品和服务遍及100多个国家和地区

Coreat goes to the world, and its products and services are in more than 100 countries and regions



广东科励宝舞台科技有限公司是一家集研发、设计、生产、销售、安装调试、技术服务于一体的高新技术企业。公司拥有专业的技术团队和一流的生产设备，始终将技术创新作为企业发展的核心驱动力，凭借多年的经验积累和技术创新，为国内外客户提供了高品质的舞台电动葫芦。

我们实施严谨的品质管理，产品已通过欧盟国际CE认证、SGS检测、国家起重运输机械质量检测，并在多个方面取得了显著的科研成果，荣获多项专利技术。产品广泛应用于礼堂剧院、演播厅、体育场馆、娱乐酒吧派对场、展览展示厅、流动演出等领域。

多年来，公司以优良的品质和严格的标准赢得了行业认可，受到社会各界的好评，是广东演艺设备行业商会理事单位、广东省广西商会演艺设备专业委员执行会长单位。高质量的产品和过硬的服务在国际上备受专业用户的欢迎和推崇。

Guangdong Coreat Stage Technology Co., Ltd. is a high-tech enterprise integrating R&D, design, production, sales, installation and commissioning, and technical services. The company has a professional technical team and first-class production equipment, always take technological innovation as the core driving force of enterprise development, with years of experience accumulation and technological innovation, to provide high-quality stage electric hoist for domestic and foreign customers.

We implement strict quality management, and our products have passed the EU international CE certification, SGS testing, and national lifting and transportation machinery quality testing, and have achieved remarkable scientific research results in many aspects, and won a number of patented technologies. The products are widely used in auditoriums, theaters, studios, stadiums, entertainment bars, party venues, exhibition halls, mobile performances and other fields.

Over the years, the company has won industry recognition with excellent quality and strict standards, and has been well received by all walks of life. High-quality products and excellent services are welcomed and respected by professional users in the world.

# 公司荣誉

## Corporate honor

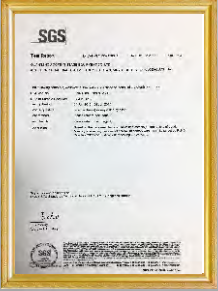
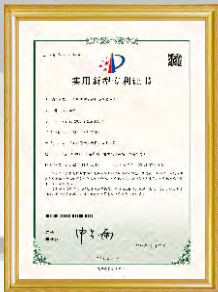
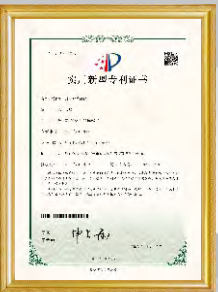
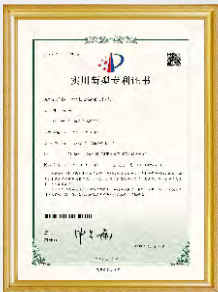
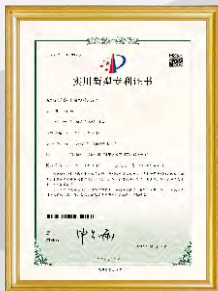



## 品牌保障品质 · 品质决定未来

相信品牌的力量，我们是行业高标准的缔造者。Ensure the

for performances.

BRAND GUARANTEES QUALITY

QUALITY DETERMINES THE FUTURE

Believing in the power of brand,  
we are the creators of high standards in the industry.





## COREAT 环链电动葫芦

### COREAT electric chain hoist

Coreat推出第4代高品质铝合金铸造成型电动葫芦，欧洲标准、外观欧式设计风格，新颖美观大方，易于安装使用，操控便捷，IP66防护等级结构设计，安全稳定的专利刹车系统，配套智能操作系统，让演出升降吊挂智能简单化。

Coreat launched the 4th generation of high-quality aluminum alloy casting and forming electric hoist, European standard, appearance European design style, novel and beautiful, easy to install and use, convenient control, IP66 protection level structure design, safe and stable patented braking system, supporting intelligent operating system, so that the performance lifting and hanging intelligent simplification.

### 优势 / Advantage

整体机身全铝合金铸造工艺，是舞台行业环链电动葫芦中机身最厚实的，IP66防护等级和坚固的机身结构，意味着它非常适合室内、户外流动使用。免维护油浸式静音齿轮箱，Coreat专利自带离合器刹车系统，G100级镀锌起重链条具有高耐腐蚀性和干运行性能，Coreat设计独特负载吊钩加厚型安全舌片。

The whole fuselage is made of aluminum alloy, which is the thickest in the electric chain hoist in the stage industry, with IP66 protection level and solid fuselage structure, which means that it is very suitable for indoor and outdoor mobile use. Maintenance-free oil-immersed silent gearbox, Coreat's patented clutch brake system, G100 galvanized lifting chain for high corrosion resistance and dry running performance, Coreat's unique load hook thickened safety tongue.





## 可靠持久

永久润滑齿轮箱

190V直流弹簧式制动器

操作安全性高

带安全保护模块式制动器电路板

铸造铝外壳和盖子

耐腐蚀型起重链条

带安全卡舌的吊钩

## 易于操作

无需改装即正挂或倒挂自爬式使用

内置4触点高精度凸轮行程限位器（选配）

采用三级传动斜齿轮传动，运行安静

防护等级为IP66室外使用

标配排水系统

无需特殊维护工具

易于维护的干式限载离合器

吊钩可360度旋转

配套提手

## 定制

三相400V或三相220V电压

直接或接触器控制

特殊控制电压

特殊控制

特殊速度

提升高度可达100米

箱体吊钩可改钢板式

加装编码器

各种配件和选项

## Reliable and long-lasting

Permanently lubricated gearbox

190V DC spring brake

High operational safety

Modular brake circuit board with safety protection

Cast aluminium casing and lid

Corrosion-resistant lifting chain

Hook with safety tab

## Easy to operate

It does not need to be modified, and it can be used upright or upside down for self-crawling

Built-in 4-contact high-precision cam travel limiter (optional)

It adopts three-stage transmission helical gear transmission, quiet operation

The degree of protection is IP66 for outdoor use

Drainage system as standard

No special maintenance tools are required

Dry load-limited clutch for easy maintenance

The hook can be rotated 360 degrees

Matching handle

## Customize

Three-phase 400V or three-phase 220V voltage

Direct or contactor control

Special control voltage

Special controls

Special speed

The lifting height can reach 100 meters

The box hook can be changed to steel plate type

Retrofit an encoder

Variety of accessories and options

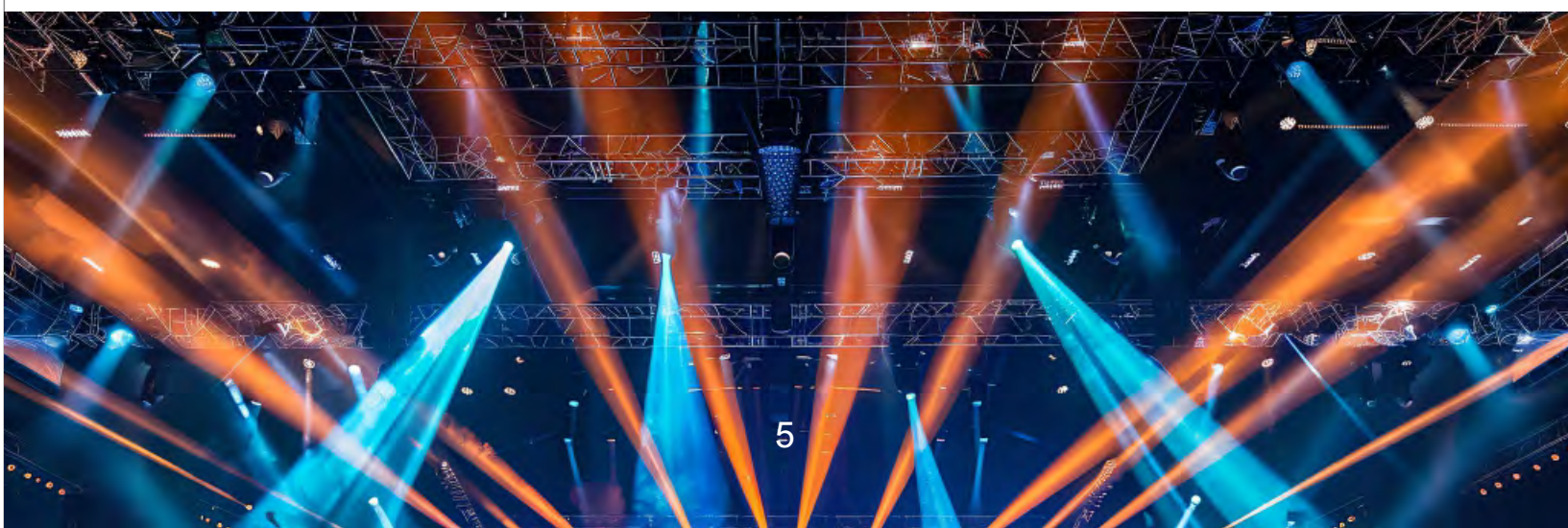

## 电动葫芦设备部件/Electric hoist equipment parts



结构设计合理，加快检修效率，电机、电路板、刹车系统独立设计，高力矩直流电刹车，为长时间使用提高寿命。双层双向自动修正防卡链系统，高强度耐磨尼龙材料，整体一次性注塑成型，维护更换简单。

The structure design is reasonable, the maintenance efficiency is accelerated, the motor, circuit board and brake system are independently designed, and the high-torque DC brake improves the life for long-term use.

Double-layer two-way automatic correction anti-jam chain system, high-strength wear-resistant nylon material, overall one-time injection molding, simple maintenance and replacement.



### 电机 / Motor

1. F级绝缘耐高温电机线圈 2. H级耐高温电机引出线。

1. F-class insulated high-temperature resistant motor coil
2. H-class high-temperature resistant motor lead-out wire.



### 双刹车系统 / Dual brake system

双刹车系统采用直流电磁4摩擦片式，间隙可调，安全系数更高。

The dual braking system adopts DC electromagnetic 4 friction plate type, with adjustable clearance and higher safety factor.



### 传动装置 / Transmissions

硬质铬锰钢高精度斜齿轮传动，齿轮箱机油永久润滑，耐磨静音。

Hard chromium-manganese steel high-precision helical gear transmission, gearbox oil is permanently lubricated, wear-resistant and silent.



### 起重链条 / Lifting chains

8倍安全系数G100级优质合金钢起重专用链条，破断强度1000N/mm<sup>2</sup>。链条符合DIN5687、DIN5688德国标准和ISO3067中国标准。

8 times the safety factor G100 grade high-quality alloy steel lifting chain, breaking strength 1000N/mm<sup>2</sup>. The chain complies with DIN5687, DIN5688 German standards and ISO3067 Chinese standards.



### 链轮 / Sprocket

5窝起重链轮，加工中心一次性成型，增加链条与齿轮啮合，确保链条平稳运行。

5 nests of lifting sprockets, the machining center is formed at one time, and the chain and gear meshing are increased to ensure the smooth operation of the chain.

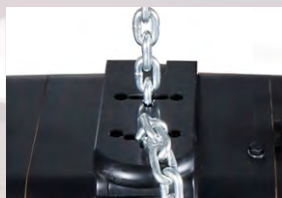

### 导链系统 / Chain guide system

双层自动修正防卡链系统，耐磨尼龙材料，整体注塑成型及CNC精密加工，优化更换维护。

Double layer automatic correction anti jamming chain system, wear-resistant nylon material, integrated injection molding and CNC precision machining, optimized for replacement and maintenance.



## 电动葫芦设备部件 / Electric hoist equipment parts



### 集成式电机、制动器电路板 / Integrated motor and brake circuit board

集成式的电机、制动器，可快速发现问题和快速检修。

Integrated motors and brakes for quick problem detection and quick overhaul.



### 齿轮限位开关 (普通型) / Gear limit switch (ordinary type)

双触点普通型齿轮限位开关，限位行程25米内，升降定位精度±10mm。

Two contact ordinary gear limit switch, with a limit stroke of within 25 meters and a lifting positioning accuracy of ±10mm.



### 齿轮限位开关 (精密型) / Gear limit switch (Precision type)

4触点高精度行星凸轮行程限位器，限位行程60米内，升降定位精度±2mm。

4-contact high-precision planetary cam travel limiter, with a limit travel of within 60 meters and a lifting positioning accuracy of ±2mm.



### 电动葫芦控制盒 / Electric hoist control box

用于控制1台或2台电动葫芦，防水航空插头。

Used to control one or two electric hoists, waterproof aviation plugs.



### 电动葫芦连接电缆 / Electric hoist connection cable

16A-4芯航空插头，4×1.5mm<sup>2</sup>国标电缆。

16A-4 core aviation plug, 4x1.5mm<sup>2</sup> national standard cable



### 分支连接电缆 / Branch connection cable

控制器输出或16芯电缆连接分支电缆，集成端16芯插头，分支端4芯航空插头，4×1.5mm<sup>2</sup>国标电缆。

Controller output or 16 core cable connection branch cable, integrated end 16 core plug, branch end 4 core aviation plug, 4 × 1.5mm<sup>2</sup> national standard cable.



### 电动葫芦航空箱 / Electric hoist flight case

1.箱内有保护胶棉。2.四个把手和万向脚轮。3.便于搬运及流动演出使用。4.箱盖装有轮窝，可上下叠起，方便储运。

1.The box contains protective collodion. 2.Four handles and casters. 3.Easy to carry and flow performance. 4.The cover is equipped with a wheel nest, which can be stacked up and down for convenient storage and transportation.

## 电动葫芦设备部件/Electric hoist equipment parts



### 卸扣 / Shackle

1.美标D型。 2.产品优质合金锻造，表面电镀处理。 3.强度80等级，4倍安全系数。

1. American Standard D-type. 2. Products of high-quality alloy forging, surface plating treatment. 3. Strength 80 grade, 4 times safety factor.



### 链袋 / Chain bag

可拆卸的高强度黑色PVC涂层布制成。

Removable high strength black Pvc coated fabric made of.



### 圆形吊装带 / Round lifting strap

采用高强度聚酯工业长丝(100%涤纶丝)制成，内部承载心无极环绕循环状构成，外部使用100%PES织成不受力套管对承载芯加以保护。符合欧洲标准EN1492-2:2000和中国行业标准JB/T8521-2007。

It is made of high-strength polyester industrial filament (100% polyester yarn), with an internal bearing center that is infinitely surrounded by a circulation, and an external 100% PES woven into a forceless sleeve to protect the bearing core. Comply with the European standard EN1492-2:2000 and the Chinese industry standard JB/T8521-2007.



### 电缆收线滑块/ Cable winding slider

6×18,7×22链条使用电缆收线滑块

6 × 18, 7 × 22 chains use cable winding sliders



### 负载传感器/ Cable winding slider

承重量程：1T、2T，电流输出：4--20mA

Load bearing range: 1T, 2T, current output: 4-20mA



## D8 标准/Standard

Coreat D8葫芦是根据EN 14492-2:2019, EN60204, DIN56950标准, 专门为在流动演出中提升设备载荷而设计的标准环链电动葫芦。无需任何改动即可固定吊装或自爬式使用。

The Coreat D8 hoist is a standard electric chain hoist designed to lift equipment loads during mobile performances according to EN 14492-2:2019, EN60204, DIN56950 standard. It can be fixed hoisted or used in self-climbing mode without any changes.

标准规格	Standard Specifications
D8环链电动葫芦符合EN14492, EN60204, DIN56950标准	D8 electric chain hoist EN14492, EN60204, DIN56950 standard
标准电压:400V/3Ph/50Hz, 220V/3Ph/60Hz	Standard voltage: 400V/3Ph/50Hz, 220V/3Ph/60Hz
单个DC190V直流制动器	Single DC190V DC brake
直接控制	Direct control
适用于变频器模式	Suitable for inverter mode
铝合金机身外壳和箱盖	Aluminum alloy body shell and box cover
外壳、部件均为黑色(链条可定制黑色)	The shell and parts are black (the chain can be customized black)
机身安装吊眼板或吊钩	The fuselage is equipped with a lifting eye plate or hook
用于正挂固定式或倒挂自爬式	It is used for upright fixed or upside-down self-climbing
防护等级IP66	Degree of protection Ip66
绝缘等级F(电机)	Insulation class F (motor)
附加耐磨板导链装置	Additional wear plate chain guide device
适用室外的排水装置	Suitable for outdoor drainage
超载离合器(非受力部件)	Overload clutch (non-stressed part)

配件和选配件	Accessories and options
世界各地的工作和控制电压均可选	Operating and control voltages are available anywhere in the world
齿轮传动限位开关	Gear drive limit switches
链轮轴上的编码器安装架	Encoder mount on sprocket shaft
增量式编码器或绝对值编码器	Incremental or absolute encoders
负载传感器4-20mA	Load cell 4-20mA
吊带	Suspenders
手柄	handle
航空箱	Airbox
控制器	Controller
带插头的供电和控制电缆	Power supply and control cables with plugs

## D8+ 标准/Standard

Coreat D8+葫芦是根据EN 14492-2:2019, SOP2:2018, EN60204-32:2008标准, 专门为在人员上方静吊载荷而开发、定级和设计的高标准环链电动葫芦。它轻巧、紧凑, 方便流动性或固定安装应用, 所有受力零件基于静态下标准载荷的双倍安全级别。

The Coreat D8+ hoist is a high-standard electric chain hoist developed, graded and designed according to EN 14492-2:2019, SOP2:2018, EN60204-32:2008 standards specifically for static lifting of loads above personnel. It is lightweight, compact and convenient for mobile or fixed installation applications, and all stressed parts are based on a double safety level for standard loads at static conditions.

标准规格	Standard Specifications
D8+环链电动葫芦符合EN14492, EN60204, DIN56950标准	D8+ electric chain hoist EN14492, EN60204, DIN56950 standard
标准电压:400V/3Ph/50Hz, 220V/3Ph/60Hz	Standard voltage: 400V/3Ph/50Hz, 220V/3Ph/60Hz
两个DC190V直流制动器	Two DC190V DC brakes
直接控制	Direct control
适用于变频器模式	Suitable for inverter mode
铝合金机身外壳和箱盖	Aluminum alloy body shell and box cover
外壳、部件均为黑色 (链条可定制黑色)	The shell and parts are black (the chain can be customized black)
机身安装吊眼板或吊钩	The fuselage is equipped with a lifting eye plate or hook
用于正挂固定式或倒挂自爬式	It is used for upright fixed or upside-down self-climbing
防护等级IP66	Degree of protection Ip66
绝缘等级F(电机)	Insulation class F (motor)
附加耐磨板导链装置	Additional wear plate chain guide device
适用室外的排水装置	Suitable for outdoor drainage
超载离合器 (非受力部件)	Overload clutch (non-stressed part)

配件和选配件	Accessories and options
世界各地的工作和控制电压均可选	Operating and control voltages are available anywhere in the world
齿轮传动限位开关	Gear drive limit switches
链轮轴上的编码器安装架	Encoder mount on sprocket shaft
增量式编码器或绝对值编码器	Incremental or absolute encoders
负载传感器4-20mA	Load cell 4-20mA
吊带	Suspenders
手柄	handle
航空箱	Airbox
控制器	Controller
带插头的供电和控制电缆	Power supply and control cables with plugs



## C1 标准/Standard

Coreat C1葫芦是根据EN 14492-2:2019, SOP2:2018, EN60204-32:2008标准, 专门为在人员上方动态吊载荷而开发、定级和设计的高标准环链电动葫芦。它轻巧、紧凑, 方便流动性或固定安装群组动态升降应用, 安全系数10:1, 最高速度达32m/min。

The Coreat C1 hoist is developed and graded according to the EN 14492-2:2019, SOP2:2018, EN60204-32:2008 standards, specifically for dynamic lifting of loads above personnel And the high standard chain electric hoist designed. It is lightweight and compact, convenient for mobility or dynamic lifting applications with fixed installation groups, with a safety factor of 10:1 and a maximum speed of 32m/min.

标准规格	Standard Specifications
C1环链电动葫芦符合EN14492,EN60204,DIN56950标准	C1 electric chain hoist meets EN14492, EN60204, DIN56950 standards
标准电压:400V/3Ph/50Hz, 220V/3Ph/60Hz	Standard voltage: 400V/3Ph/50Hz, 220V/3Ph/60Hz
两个DC190V直流制动器	Two DC190V DC brakes
直接控制	Direct control
适用于变频器模式	Suitable for inverter mode
铝合金机身外壳和箱盖	Aluminum alloy body shell and box cover
外壳、部件均为黑色(链条可定制黑色)	The shell and parts are black (the chain can be customized black)
机身安装吊眼板或吊钩	The fuselage is equipped with a lifting eye plate or hook
用于正挂固定式或倒挂自爬式	It is used for upright fixed or upside-down self-climbing
防护等级IP66	Degree of protection Ip66
绝缘等级F(电机)	Insulation class F (motor)
附加耐磨板导链装置	Additional wear plate chain guide device
适用室外的排水装置	Suitable for outdoor drainage
超载离合器(非受力部件)	Overload clutch (non-stressed part)

配件和选配件	Accessories and options
世界各地的工作和控制电压均可选	Operating and control voltages are available anywhere in the world
在 50 Hz 下速度达 32 m/min	Speeds of up to 32 m/min at 50 Hz
齿轮传动限位开关(精密型)	Gear drive limit switch (precision type)
链轮轴上的编码器安装架	Encoder mount on sprocket shaft
增量式编码器或绝对值编码器	Incremental or absolute encoders
负载传感器0-10V或4-20mA	Load cell 0-10V or 4-20mA
吊带	Suspenders
手柄	handle
航空箱	Airbox
控制器	Controller
带插头的供电和控制电缆	Power supply and control cables with plugs



## V02 产品主要技术参数 / Main technical parameters of the product

型号 Model	额定负载 Rated load (kg)	提升速度 Lifting Speed (m/min)	工作电压 Power supply	电机功率 Motor power (kw)	链条规格 Chain specification (mm)	链条安全系数 Chain safety factor	链条数 Chain Qty	葫芦重量 Hoist weight (kg)	链条重量 Chain weight (kg/m)	防护等级 Degree of protection	绝缘等级 Insulation class	刹车系统 Braking system	安全保护 safety protection
V02 D8	250	4	400V/50Hz/3P	0.2	5×15	8	1	13.3	0.5	IP66	F	单 single	离合器过载保护 Clutch overload protection
V02 D8+	250	4	220V/60Hz/3P	0.2	5×15	8	1	15.3	0.5	IP66	F	双 double	

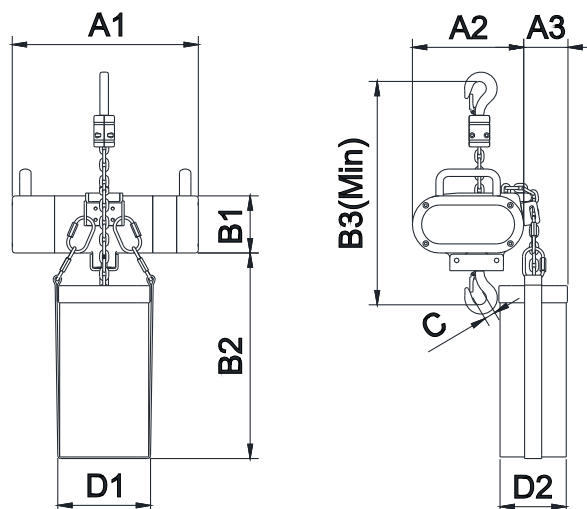

Unit:mm

Model	A1	A2	A3	B1	B2	B3	C	D1	D2
V02 D8	328	195	77	100	360	350	20	160	120
V02 D8+	372	195	77	100	360	350	20	160	120



## V05 产品主要技术参数 / Main technical parameters of the product

型号 Model	额定负载 Rated load (kg)	提升速度 Lifting Speed (m/min)	工作电压 Power supply	电机功率 Motor power (kw)	链条规格 Chain specification (mm)	链条安全系数 Chain safety factor	链条数 Chain Qty	葫芦重量 Hoist weight (kg)	链条重量 Chain weight (kg/m)	防护等级 Degree of protection	绝缘等级 Insulation class	刹车系统 Braking system	安全保护 safety protection
V05 D8	500	4	400V/50Hz/3P 220V/60Hz/3P	0.4	6×18	8	1	23	0.75	IP66	F	单 single	离合器过载保护 Clutch overload protection
V05 D8+	500	4		0.4	6×18	8	1	28	0.75	IP66	F	双 double	
V05H D8	250	8		0.4	6×18	8	1	23	0.75	IP66	F	单 single	
V05H D8+	250	8		0.4	6×18	8	1	28	0.75	IP66	F	双 double	
V05 C1	250	16		1.1	6×18	10	1	31	0.75	IP66	F	双 double	离合器过载保护 限位器, 编码器 Clutch overload protection Limit switch Encoder

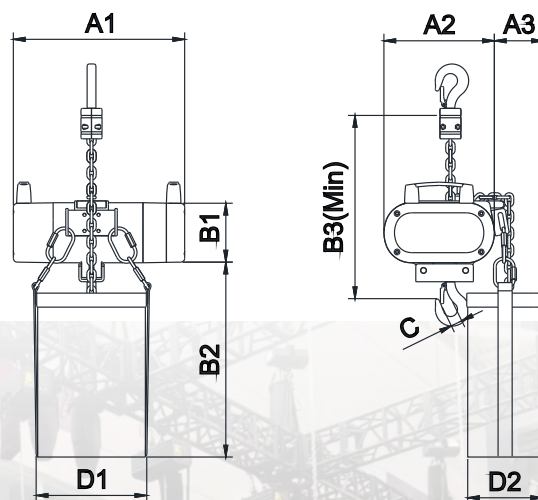

Unit:mm

Model	A1	A2	A3	B1	B2	B3	C	D1	D2
V05 D8	366	236	105	128	470	450	25	240	160
V05 D8+	416	236	105	128	470	450	25	240	160
V05 C1	516	236	105	128	470	450	25	240	160

## V10 产品主要技术参数 / Main technical parameters of the product

型号 Model	额定负载 Rated load (kg)	提升速度 Lifting Speed (m/min)	工作电压 Power supply	电机功率 Motor power (kw)	链条规格 Chain specification (mm)	链条安全系数 Chain safety factor	链条数 Chain Qty	葫芦重量 Hoist weight (kg)	链条重量 Chain weight (kg/m)	防护等级 Degree of protection	绝缘等级 Insulation class	刹车系统 Braking system	安全保护 safety protection
V10 D8	1000	4	400V/50Hz/3P 220V/60Hz/3P	0.75	7×22	8	1	32	1	IP66	F	单 single	离合器过载保护 Clutch overload protection
V10 D8+	1000	4		0.75	7×22	8	1	39	1	IP66	F	双 double	
V10H D8	500	8		0.75	7×22	8	1	32	1	IP66	F	单 single	
V10H D8+	500	8		0.75	7×22	8	1	39	1	IP66	F	双 double	
V10 C1	500	16		2.2	7×22	10	1	45	1	IP66	F	双 double	离合器过载保护 限位器, 编码器 Clutch overload protection Limit switch Encoder

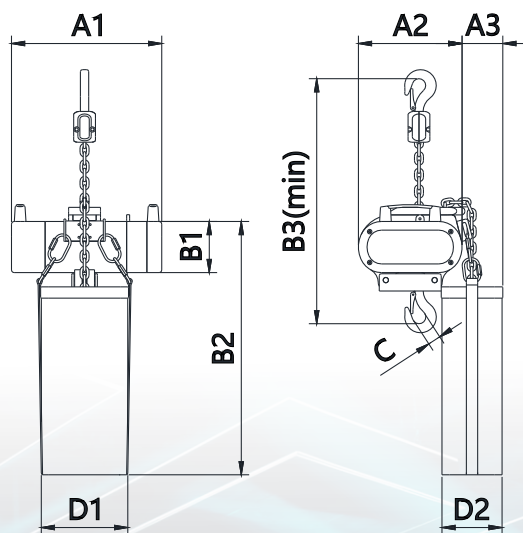

Unit:mm

Model	A1	A2	A3	B1	B2	B3	C	D1	D2
V10 D8	400	276	110	136	680	550	35	240	160
V10 D8+	460	276	110	136	680	550	35	240	160
V10 C1	520	276	110	136	680	550	35	240	160

深圳家居设计周  
暨深圳国际家具展  
SHENZHEN CREATIVE WEEK



## C10 产品主要技术参数 / Main technical parameters of the product

型号 Model	额定负载 Rated load (kg)	提升速度 Lifting Speed (m/min)	工作电压 Power supply	电机功率 Motor power (kw)	链条规格 Chain specification (mm)	链条安全系数 Chain safety factor	链条数 Chain Qty	葫芦重量 Hoist weight (kg)	链条重量 Chain weight (kg/m)	防护等级 Degree of protection	绝缘等级 Insulation class	刹车系统 Braking system	安全保护 safety protection
C10 D8	1000	4	400V/50Hz/3P 220V/60Hz/3P	0.75	7×22	8.95	1	32	1	IP66	F	单 single	离合器过载保护 Clutch overload protection
C10 D8+	1000	4		0.75	7×22	8.95	1	39	1	IP66	F	双 double	
C10H D8	500	8		0.75	7×22	8.95	1	32	1	IP66	F	单 single	
C10H D8+	500	8		0.75	7×22	8.95	1	39	1	IP66	F	双 double	

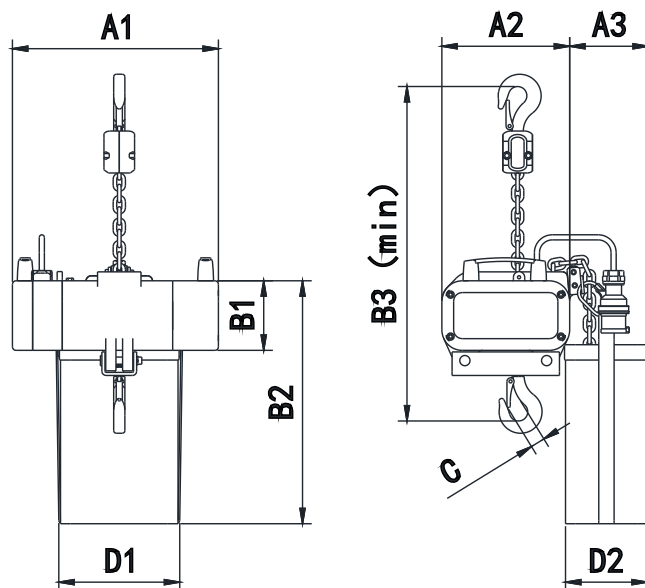

Unit:mm

Model	A1	A2	A3	B1	B2	B3	C	D1	D2
C10 D8	400	250	150	136	680	550	35	240	160
C10 D8+	460	250	150	136	680	550	35	240	160



## V20 产品主要技术参数 / Main technical parameters of the product

型号 Model	额定负载 Rated load (kg)	提升速度 Lifting Speed (m/min)	工作电压 Power supply	电机功率 Motor power (kw)	链条规格 Chain specification (mm)	链条安全系数 Chain safety factor	链条数 Chain Qty	葫芦重量 Hoist weight (kg)	链条重量 Chain weight (kg/m)	防护等级 Degree of protection	绝缘等级 Insulation class	刹车系统 Braking system	安全保护 safety protection
V20D8+	2000	4	400V/50Hz/3P 220V/60Hz/3P	2.2	10×30	8	1	88	2	IP66	F	双 double	离合器过载保护 Clutch overload protection
V20H D8+	1000	8		2.2	10×30	8	1	88	2	IP66	F	双 double	
V20-2D8+	4000	2		2.2	10×30	8	2	93	2	IP66	F	双 double	

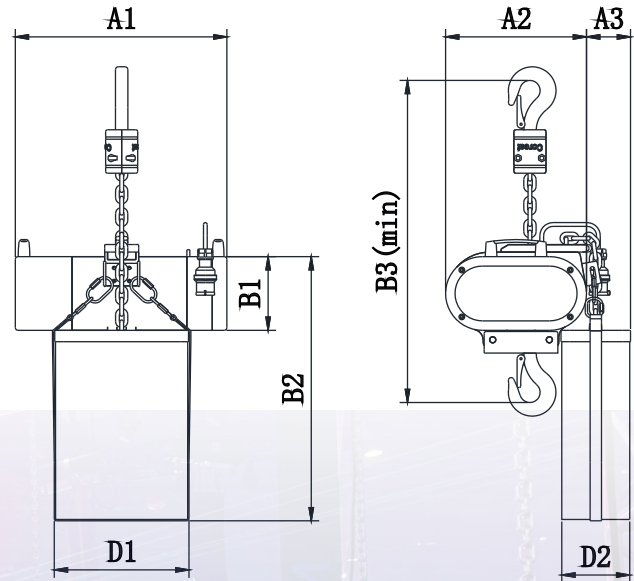

Unit:mm

Model	A1	A2	A3	B1	B2	B3	C	D1	D2
V20 D8+	560	373	120	195	680	750	40	350	180
C20-2 D8+	560	373	120	195	780	850	50	350	180

## E10 产品主要技术参数 / Main technical parameters of the product

型号 Model	额定负载 Rated load (kg)	提升速度 Lifting Speed (m/min)	工作电压 Power supply	电机功率 Motor power (kw)	链条规格 Chain specification (mm)	链条安全系数 Chain safety factor	链条数 Chain Qty	葫芦重量 Hoist weight (kg)	链条重量 Chain weight (kg/m)	防护等级 Degree of protection	绝缘等级 Insulation class	刹车系统 Braking system	安全保护 safety protection
E10 D8	1000	4	400V/50Hz/3P 220V/60Hz/3P	0.75	7×22	8	1	35	1	IP54	F	单 single	离合器过载保护 Clutch overload protection

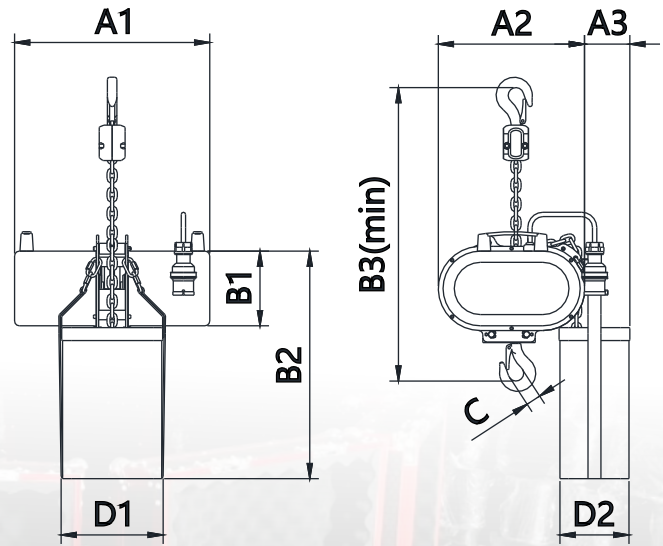

Unit:mm

Model	A1	A2	A3	B1	B2	B3	C	D1	D2
E10 D8	455	340	105	173	680	700	30	240	160



## 》》》 C1 PLUS智能数控葫芦/C1 PLUS Intelligent CNC hoist

Coreat C1 PLUS智能数控电动葫芦，搭载国际通用最新的EtherCAT总线伺服系统，智能的运动控制方式和紧凑的一体化设计，轻质高强度铝合金壳体，可满足在大型活动、演唱会、电视节目及固定安装项目使用，产品具有超静音、易操作、绝对值编码器精确定位的特点，最高速度32m/min，平滑精准的2D和3D运动更好的提升整体创意和舞台艺术呈现。

Coreat C1 PLUS intelligent CNC electric hoist, equipped with the latest internationally recognized EtherCAT bus servo system, intelligent motion control mode and compact integrated design, lightweight High strength aluminum alloy shell, suitable for use in large-scale events, concerts, TV programs, and fixed installation projects. The product has ultra quiet, easy to operate, and precise positioning of absolute value encoders. Features: With a maximum speed of 32m/min, smooth and precise 2D and 3D movements better enhance overall creativity and stage art presentation.

## 》》》 优势&功能/Advantages&Features

- 1.正挂悬吊方式
- 2.EtherCAT总线伺服电机
- 3.多圈绝对值编码器重复定位精度 $\pm 1\text{mm}$
- 4.符合国际安全标准:EN14492,EN60204, DIN56950
- 5.DAT级镀锌起重链条(国产或进口链条可选)
- 6.即插即用，控制台自动配置设备编号
- 7.简单接线，即插式电源、网线输入、输出端口

- 1.Straight hanging hanging mode
- 2.EtherCAT bus servo motor
- 3.Repeated positioning accuracy of multi turn absolute value encoder  $\pm 1\text{mm}$
4. Complies with international safety standards: EN14492, EN60204, DIN56950
- 5.DAT grade galvanized lifting chain(Domestic or imported chains are optional)
6. Plug and play, the console automatically configures device numbers
7. Simple wiring, plug in power supply, network cable input, output ports

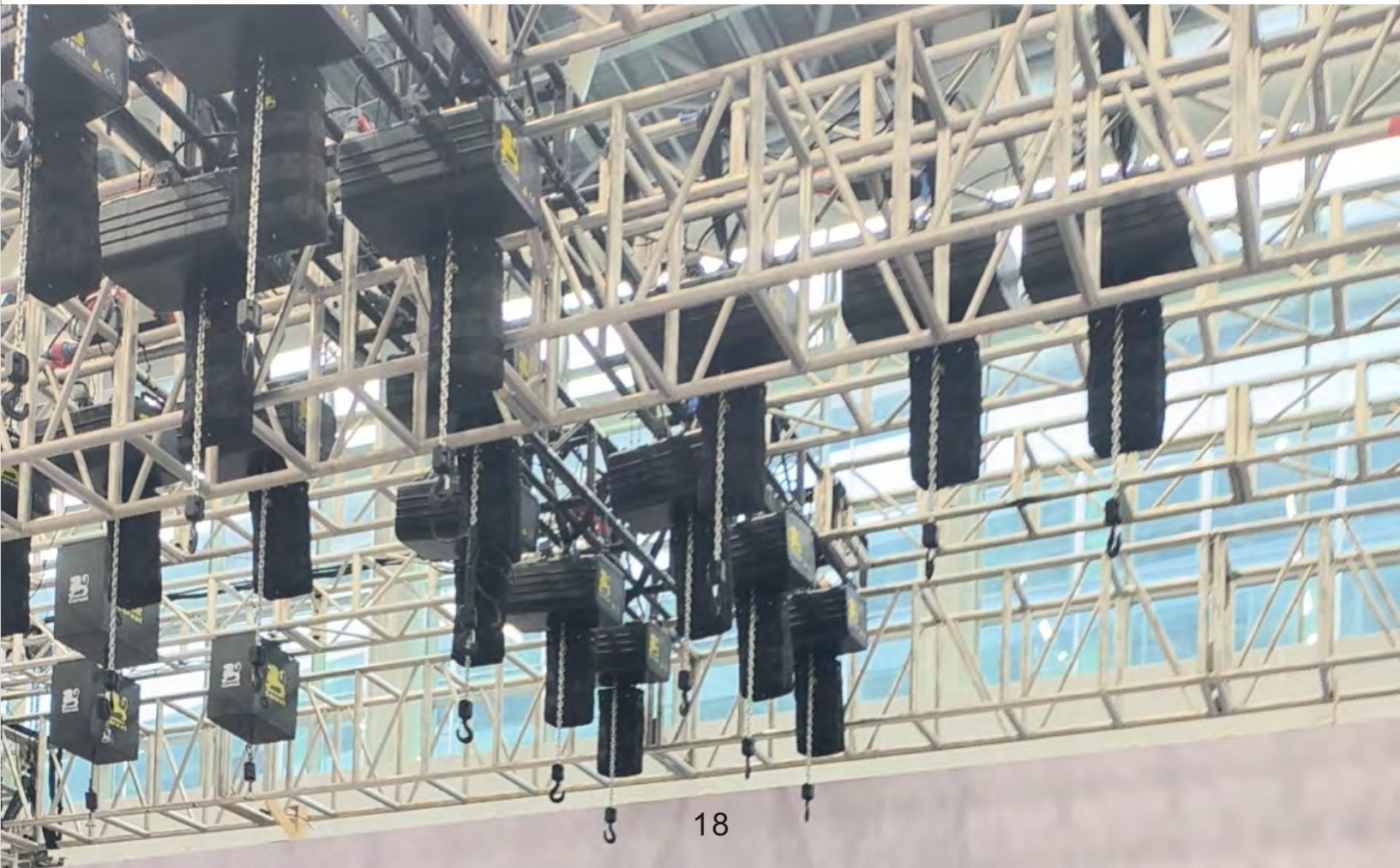

## 产品主要技术参数 / Main technical parameters of the product

型号 Model	额定负载 Rated load (kg)	提升速度 Lifting Speed (m/min)	工作电压 Power supply	电机功率 Motor power (kw)	链条规格 Chain specification (mm)	链条安全系数 Chain safety factor	链条数 Chain Qty	葫芦重量 Hoist weight (kg)	链条重量 Chain weight (kg/m)	防护等级 Degree of protection	绝缘等级 Insulation class	刹车系统 Braking system	安全保护 safety protection
S810 C1 PLUS	500	8	400V/50Hz/3P 220V/60Hz/3P	1.8	7×22	10	1	59	1	IP54	F	双 double	过载保护 限位器, 编码器 Overload protection Limit switch Encoder
S1605 C1 PLUS	500	16		3	7×22	10	1	60	1	IP54	F	双 double	
S3205 C1 PLUS	500	32		4	7×22	10	1	63	1	IP54	F	双 double	

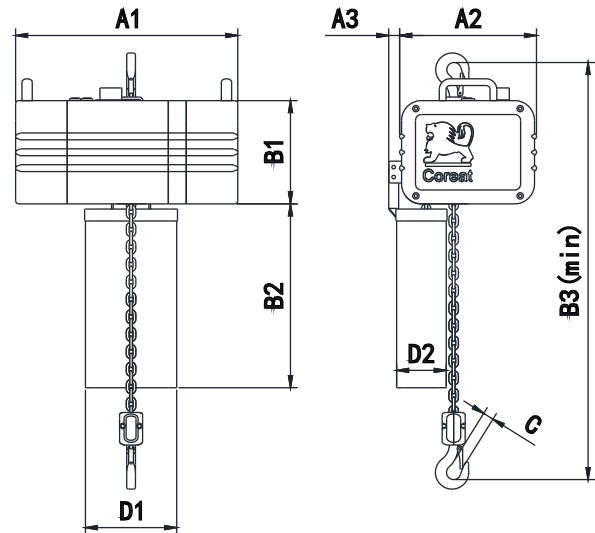

Unit:mm

Model	A1	A2	A3	B1	B2	B3	C	D1	D2
S810 C1 PLUS	560	276	110	136	680	550	35	240	160
S1605 C1 PLUS	560	276	110	136	680	550	35	240	160
S3205 C1 PLUS	650	276	110	136	680	550	35	240	160

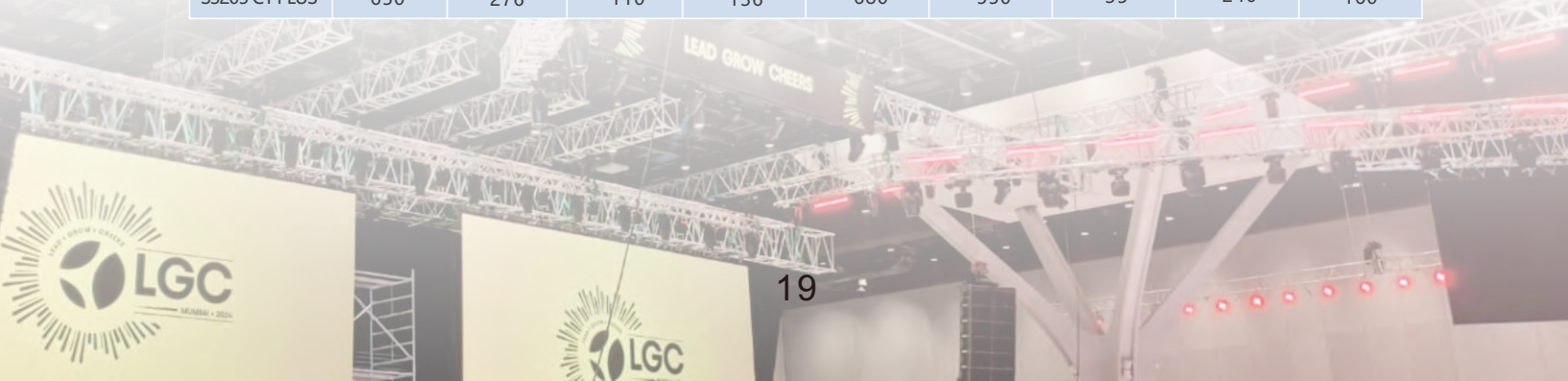

## 》》》 主要特点

- 自主研发专业机械数字控台,
- 10/15寸触摸屏(可选),
- 场景模拟软件,
- 16/32/48/64/128/256轴运动控制,
- USB插口程序导入,
- 支持DMX512、TCP等外部通讯接口协议,
- 工作电压: 100-240V (50/60Hz) ,
- 外形尺寸: W490×D280×H190mm(10寸),  
W680×D420×H230mm(15寸)

- 简单、直观、安全的布线系统
- 安装和拆卸时可对电动葫芦进行实时手动控制
- 可自由组合电动葫芦, 增加或减少电动葫芦数量, 无需重新编程
- 可选择加减速曲线, 直线插补、圆弧插补、螺旋线插补、空间圆弧
- 支持多任务, 多轴组, 多轴协同运动控制软件系统
- 远程控制可视化在线技术支持
- 软件急停或紧急停止系统
- 特制的专用航空箱, 最大限度的减少装载时间

## 智能数控葫芦系统图

Intelligent CNC hoist system diagram

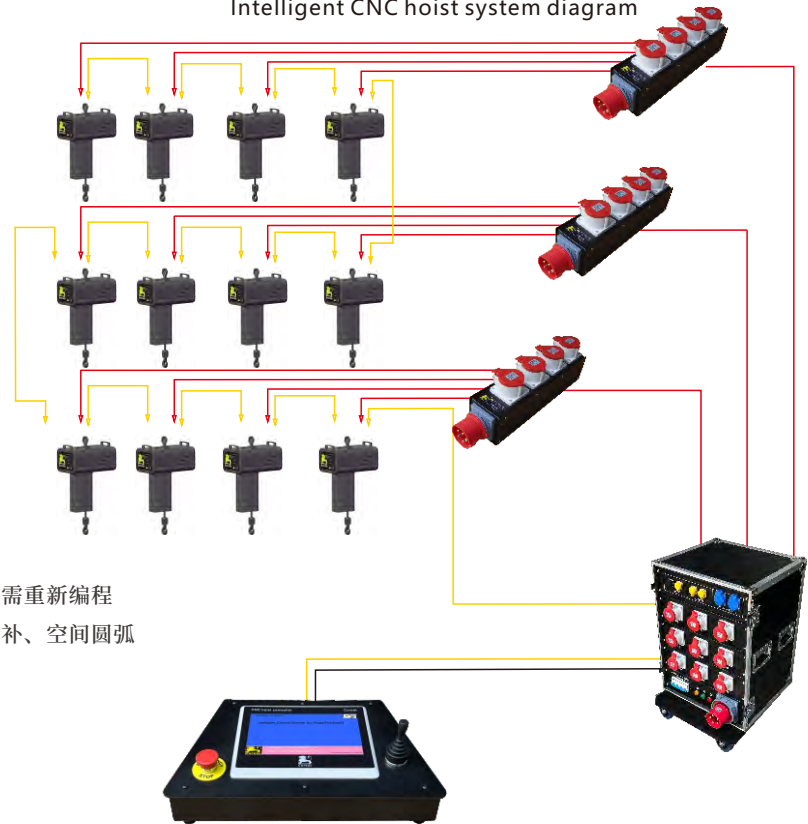

## 》》》 Main features

- Independently developed professional mechanical digital control console,
- 10/15 inch touch screen(selectable),
- Scene simulation software,
- 16/32/48/64/128/256 axis motion control,
- USB port program import,
- Supports external communication interface protocols such as DMX512 and TCP,
- Working voltage: 100-240V (50/60Hz),  
External dimensions: W490×D280×H190mm(10 inch),  
W680×D420×H230mm(15 inch),
- Simple, intuitive and safe wiring system ;
- Real-time manual control of the electric hoist during installation and disassembly ;
- The electric hoist can be combined freely to increase or decrease the number of electric hoists without reprogramming;
- Can choose acceleration and deceleration curve, linear interpolation, circular interpolation, helical interpolation, space circular arc;
- Support multi-task, multi-axis group, multi-axis cooperative motion control software system ;
- Remote Control Visualization Online Technical Support;
- Software emergency stop or emergency stop system;
- Specially dedicated air box, to minimize loading time .

## 电动葫芦控制器/Electric hoist controller



KLT-4P



KLT-8P



KLT-12P

### 主要配置与功能特点

- 1.可单台或多台电动葫芦同步升降，操控简单方便。
- 2.控制器可两台或多台联动控制。
- 3.黑色手提式防水箱，携带使用方便，外形美观。

### Main configurations and functional characteristics

1. The controller can synchronize the lifting and lowering of single or multiple electric hoists, with simple and convenient operation.
2. The controller can be linked and controlled by two or more units.
3. Black portable waterproof box, easy to carry and use, beautiful appearance.



KLT-4CP



KLT-8CP



KLT-12LP

### 主要配置与功能特点

- 1.可单台葫芦或多台同步升降，操控简单方便。
- 2.控制器可两台或多台联动控制。
- 3.定制航空箱式或16A-16芯插头，携带使用方便，外形美观。

### Main configurations and functional characteristics

1. The controller can synchronize the lifting and lowering of single or multiple electric hoists, with simple and convenient operation.
2. The controller can be linked and controlled by two or more units.
3. Customized aviation box or 16A-16 core plug, portable Easy to use and aesthetically pleasing in appearance.

## 电动葫芦控制器/Electric hoist controller



KLT-8GP

### 主要配置与功能特点

1. 手动控制与触摸屏控制切换使用
2. 单台或多台电动葫芦同时升降，操控简单方便
3. 黑色手提式防水箱，携带使用方便，外形美观。

### Main configurations and functional characteristics

1. Switching between manual control and touch screen control
2. Single or multiple electric hoists can be lifted and lowered simultaneously, with simple and convenient operation
3. Black portable waterproof box, easy to carry and use, with a beautiful appearance.



KLT-24P

### 主要配置与功能特点

1. 单台或多台电动葫芦同步升降，操控简单方便。
2. 控制器可两台或多台联动控制。
3. 流动演出机柜式，使用方便，外形美观。

### Main configurations and functional characteristics

1. Single or multiple electric hoists can be synchronously lifted and lowered, with simple and convenient operation.
2. The controller can be linked and controlled by two or more units.
3. Mobile performance cabinet style, convenient to use, and aesthetically pleasing in appearance.



KLT-4MP



KLT-8MP



KLT-12MP

### 主要配置与功能特点

1. 单台或多台电动葫芦同步升降，操控简单方便。
2. 控制器可两台或多台联动控制。
3. 标准3U机箱式。

### Main configurations and functional characteristics

1. Single or multiple electric hoists can be synchronously lifted and lowered, with simple and convenient operation.
2. The controller can be linked and controlled by two or more units.
3. Standard 3U chassis type.



## 公司环境/Electric hoist equipment parts



## 生产车间/Production workshop

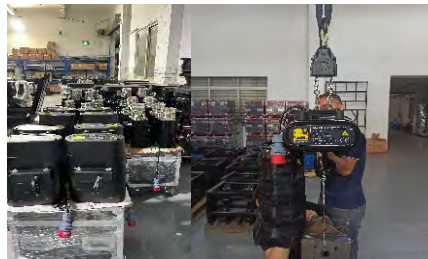



工程案例/Engineering case

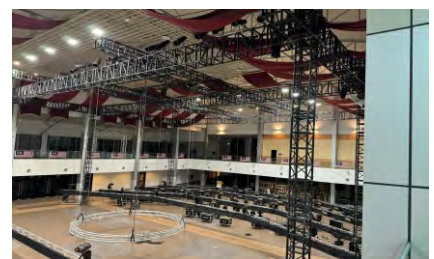
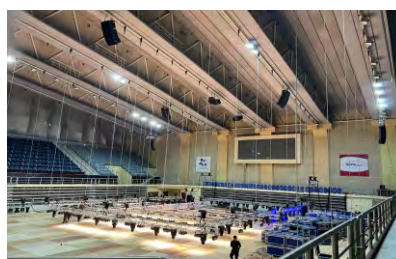
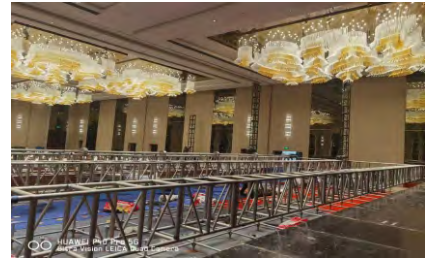
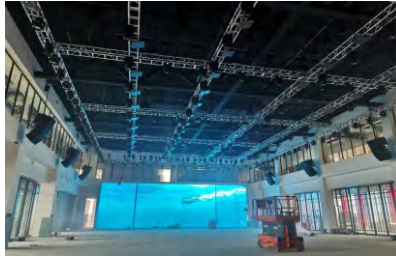
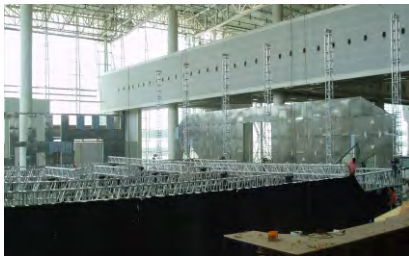
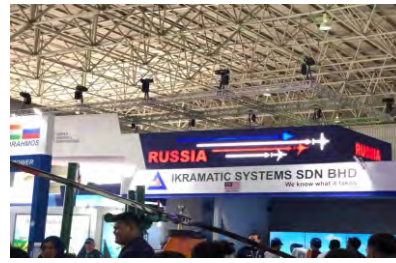
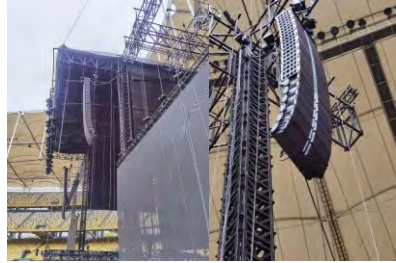



»» 工程案例/Engineering case

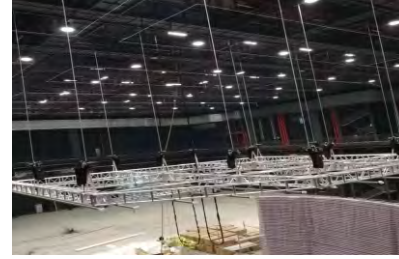
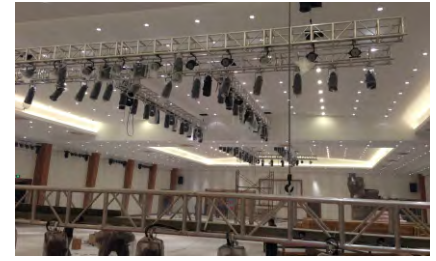
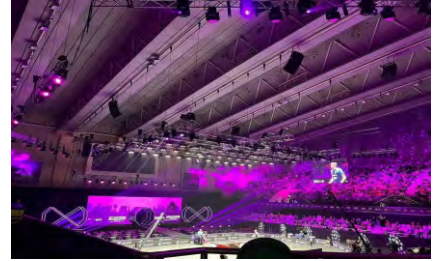
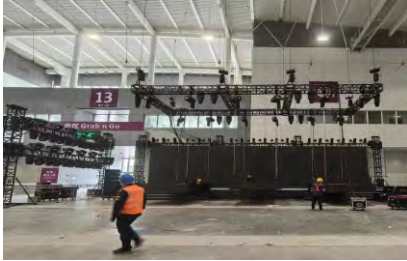



»» 工程案例/Engineering case

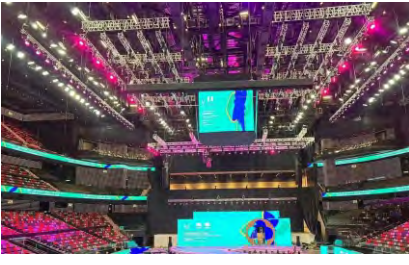
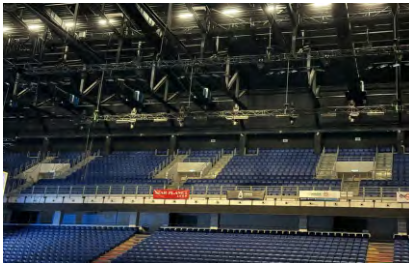
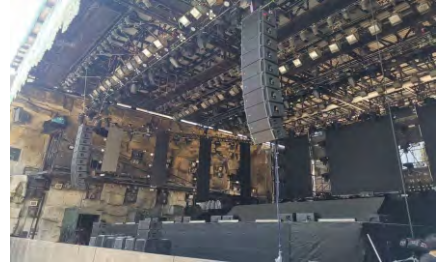

## »» 工程案例/Engineering case

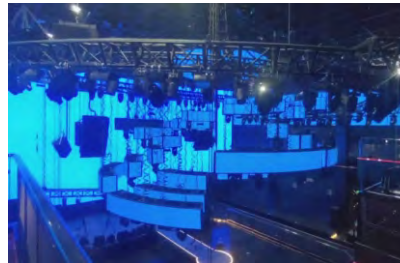
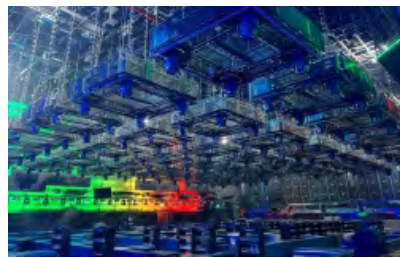
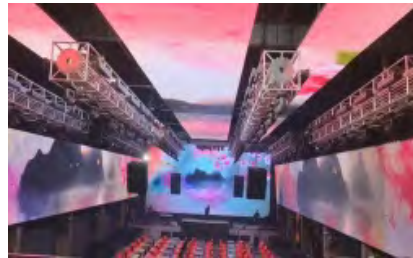
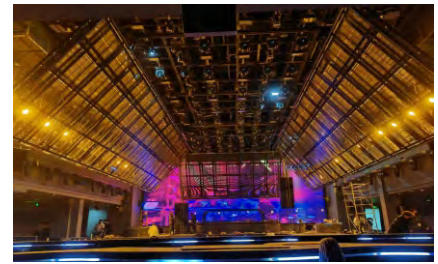
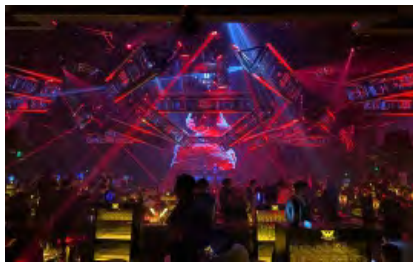



## »» 参展历程/Exhibiting history

1. 2016-03 GETshow广州展
2. 2016-04 德国法兰克福展
3. 2016-05 印度Palm Expo India
4. 2016-09 北京国际专业灯光音响展
5. 2016-10 上海国际专业灯光音响展
6. 2017-02 GETshow广州展
7. 2017-09 成都国际（音乐）演艺设备博览会
8. 2017-10 上海国际专业灯光音响展
9. 2018-05 GETshow广州展
10. 2018-09 成都国际（音乐）演艺设备博览会
11. 2018-10 上海国际专业灯光音响展
12. 2019-02 广州国际专业灯光音响展览会
13. 2019-05 GETshow广州展
14. 2019-10 上海国际专业灯光音响展
15. 2021-05 GETshow广州展
16. 2023-05 GETshow广州展
17. 2024-03 GETshow广州展

1. GET Show-Guangzhou
2. Frankfurt, Germany
3. Palm Expo India 2016
4. Beijing International Professional Lighting and Sound Exhibition
5. Shanghai International Professional Lighting and Sound Exhibition
6. GET Show-Guangzhou
7. Chengdu International (Music) Performing Arts Equipment Expo
8. Shanghai International Professional Lighting and Sound Exhibition
9. GET Show-Guangzhou
10. Chengdu International (Music) Performing Arts Equipment Expo
11. Shanghai International Professional Lighting and Sound Exhibition
12. Guangzhou International Professional Lighting and Sound Exhibition
13. GET Show-Guangzhou
14. Shanghai International Professional Lighting and Sound Exhibition
15. GET Show-Guangzhou
16. GET Show-Guangzhou
17. GET Show-Guangzhou







 020-39160788 13925081178

 [www.chinacoreat.com](http://www.chinacoreat.com)

 Email : [chinacoreat@vip.163.com](mailto:chinacoreat@vip.163.com)  
广东省广州市番禺区沙湾街青峰路2号

 2 Qingfeng Road, Shawan Street, Panyu District,  
Guangzhou city, Guangdong Province